

Universal 3 Series

ROTARY POSITIVE DISPLACEMENT PUMPS



Front Loading Seal Design

Users of Waukesha Cherry-Burrell PD pumps benefit from decades of continuing product improvement. Steady advances in design, metallurgy and fabrication techniques have yielded progressively higher levels of performance and service life.

THE UNIVERSAL 3 SERIES of pumps is the latest expression of this tradition. They combine 3-way mounting versatility introduced by the Universal I with new features that extend pump life and improve sanitary performance.

SPX FLOW, Inc. (NYSE:FLOW) is a leading manufacturer of innovative flow technologies, many of which help define the industry standard in the market segments they serve. From its headquarters in Charlotte, North Carolina, it operates a sales and support network, centers of manufacturing excellence, and advanced engineering facilities, throughout the world. Its cutting-edge flow components and process equipment portfolio includes a wide range of pumps, valves, heat exchangers, mixers, homogenizers, separators, filters, UHT, and drying technology that meet many application needs. Its expert engineering capability also makes it a premium supplier of customized solutions and complete, turn-key packages to meet the most exacting of installation demands.

Incorporating many leading brands, SPX FLOW has a long history of serving the food and beverage, power and energy, and industrial market sectors. Its designs and engineered solutions help customers drive efficiency and productivity, increase quality and reliability, and meet the latest regulatory demands. In-depth understanding of applications and processes, state-of-the-art Innovation Centers, and advanced pilot/testing technology further assist in optimizing processes and reducing timescales to reliably meet production targets.

To learn more about SPX FLOW capabilities, its latest technology innovations and complete service offerings, please visit www.spxflow.com.

A new level of sanitary performance. Long-life engineering features.

PRODUCT FEATURES AND BENEFITS

Sanitary Features

- Front loading seal design
- CIP capable standard. Pump rotor has internal flats and will free drain with vertical ports.
- Cover is free draining in horizontal or vertical port positions.
- Rotor/shaft connection is completely sealed from product zone and reduces the risk of corrosion.
- Single mechanical seals standard. Optional double mechanical seals, o-ring and lip seals also available. Ability to switch seal types without additional machining.
- Cover seal is a profile design to improve cleanability and resist particulates from being "pinched" and trapped.
- Stainless steel gear case and bearing frame standard.
- Aseptic fittings available.
- Seal flush and steam-in-place optional.

Long-life Features

- Up to 500 psi (34.5 bar) pressure capability.
- Pumps rated to 300°F (149°C) as standard.
- Special rotor nut designed for extended service without loosening.
- No bearings in the product zone.
- New shafts are shorter and have larger diameter 17-4 PH shafts:
 - » Reduces overhung load which improves shaft alignment and decreases seal and bearing wear for extended seal life.
 - » Improves shaft strength and stiffness helping to eliminate vibration
- Heavy duty stainless steel bearing frame standard.
- Double tapered roller bearings.
- Greased lubed bearings for positive lubrication to all bearings over entire speed, temperature and pressure range.
- Body retaining screws for maintaining mechanical seal contact during inspection.
- Extended outer seal life. A wave spring, instead of an O-ring, mechanically loads the seal.
- Unique mechanical seal design utilizes 2 pin stationary seal and special design shaft for rotary seal.

Installation Features

- Bidirectional flow. Rotors, locked with torqued nuts, rotate securely in either direction. No more flow direction/shaft position specifications.
- Versatile 3-Way mounting of gear case, including vertical alignment of ports.
- Upper or lower shaft position.
- Non-galling Waukesha "88" alloy rotors standard; permits running at tighter clearances and pumping a wide range of viscosities. Stainless steel rotors also available.
- 316L stainless steel pump body and cover.
- Electro-polish of product contact surfaces, optional.



Shown with standard stainless steel gearcase

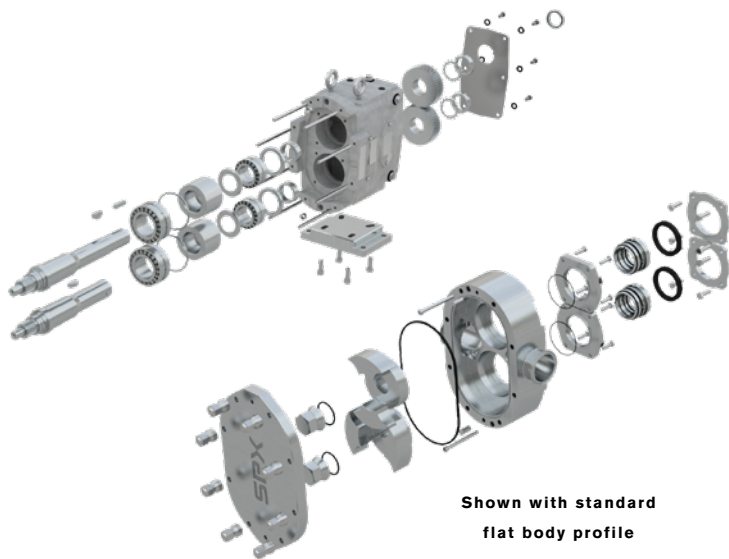

Shown with standard flat body profile

**ISO 9001
CERTIFIED**

Typical product applications

Food and Beverage

Soups, Stews, Tomato Paste
Vegetables, Dressings
Chocolate, Fats & Oils
Batters, Cream Fillings
Brewery, Wort
Soft/Fruit Drinks



Dairy

Cream, Milk
Cheese Curd & Whey
Cottage Cheese
Yogurt



Pharmaceutical/Cosmetics

Pill Pastes
Syrups, Extracts, Slurries
Face Creams & Lotions
Hair Styling Gels & Liquids
Dyes & Alcohols

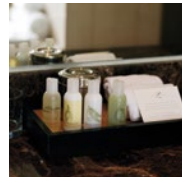

Chemical/Industrial

Solvents, Paints
Fuels
Resins, Polymers & Sludges
Oil & Lubricants
Soaps



Time-tested Waukesha Cherry-Burrell rotary pump; circumferential-piston operating principle

THEORY OF OPERATION

In the Waukesha Cherry-Burrell design, arc-shaped “pistons” (rotor wings) travel in annular-shaped cylinders machined in the pump body; the resulting long sealing path reduces slippage and produces a smooth flow of product without destructive pulses or pressure peaks and without valves or complex parts.

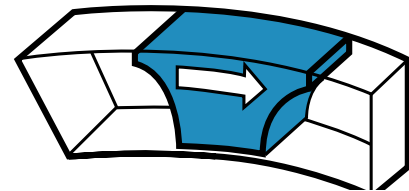

FOR LOW VISCOSITY FLUIDS

Rotors, made of Waukesha “88” alloy, can be run with close clearance to the 316L stainless steel fluid head, without galling or seizing should inadvertent pressure surges cause contact. The close clearances combined with the rotor geometry, which gives a long sealing path between the pump inlet and outlet, means low slip operation. As a result, you achieve: high efficiency, good priming ability, metering capability and good flow control.

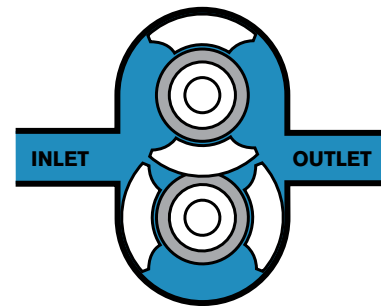

FOR HIGH VISCOSITY FLUIDS

The large fluid cavities of the rotors, plus the large easy entry anti-cavitation ports, allow efficient pumping of high viscosity fluids, slurries or even liquids with large chunks or particles.

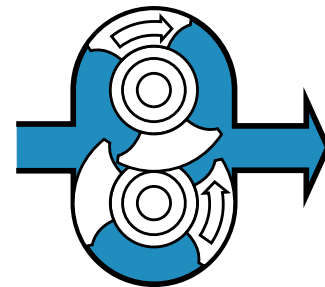

FOR NON-LUBRICATING AND ABRASIVE FLUIDS

The Waukesha Cherry-Burrell design has no bearing in the fluid being pumped, no sliding or rolling contact and no rotor-to-rotor contact. This produces MAXIMUM SERVICE LIFE even under severe operating conditions.

PRODUCT SPECIFICATIONS



UNIVERSAL 3 MODELS

MODEL	DISPLACEMENT PER REVOLUTION	NOMINAL CAPACITY TO	INLET/OUTLET	OPTIONAL INLET/OUTLET	PRESSURE RANGE UP TO*	MAXIMUM RPM	APPROX SHIP WT.	TEMP RANGE
006-U3	.0082 GAL. (.031 LITER)	8 GPM (1.8 m3/hr.)	1"	1 1/2"	300 PSI (20.7 bar)	1000	56lb (25kg)	Std Clearance Rotors: -40°F (-40°C) to 300°F (149°C)
015-U3	.0142 GAL. (.054 LITER)	11 GPM (2.5 m3/hr.)	1 1/2"	-	250 PSI (17.2 bar)	800	56lb (25kg)	
018-U3	.029 GAL. (.110 LITER)	20 GPM (4.5 m3/hr.)	1 1/2"	2"	200 PSI (13.8 bar)	700	65lb (30kg)	
030-U3	.060 GAL. (.227 LITER)	36 GPM (8.2 m3/hr.)	1 1/2"	2"	250 PSI (17.2 bar)	600	130lb (59kg)	
040-U3	.076 GAL. (.288 LITER)	46 GPM (10.4 m3/hr.)	2"	-	150 PSI (10.5 bar)	600	140lb (64kg)	
045-U3	.098 GAL. (.371 LITER)	58 GPM (13.2 m3/hr.)	2"	-	450 PSI (31.0 bar)	600	295lb (134kg)	
060-U3	.153 GAL. (.579 LITER)	90 GPM (20.4 m3/hr.)	2 1/2"	3"	300 PSI (20.7 bar)	600	285lb (129kg)	
130-U3	.253 GAL. (.958 LITER)	150 GPM (34.1 m3/hr.)	3"	-	200 PSI (13.8 bar)	600	305lb (138kg)	
180-U3	.380 GAL. (1.438 LITER)	230 GPM (52.2 m3/hr.)	3"	-	450 PSI (31.0 bar)	600	520lb (236kg)	
210-U3	.502 GAL. (1.900 LITER)	300 GPM (68.1 m3/hr.)	4"	-	500 PSI (34.5 bar)	600	915lb (415kg)	
220-U3	.521 GAL. (1.972 LITER)	310 GPM (70.4 m3/hr.)	4"	-	300 PSI (20.7 bar)	600	590lb (268kg)	
320-U3	.752 GAL. (2.847 LITER)	450 GPM (102 m3/hr.)	6"	-	300 PSI (20.7 bar)	600	895lb (406kg)	

*Contact application engineering for higher pressure or higher temperature applications.

SPX CONNECT APP

Scan QR codes to quickly retrieve manuals, lookup support contact information and request quotations for service or parts.

Download the SPX Connect App today!

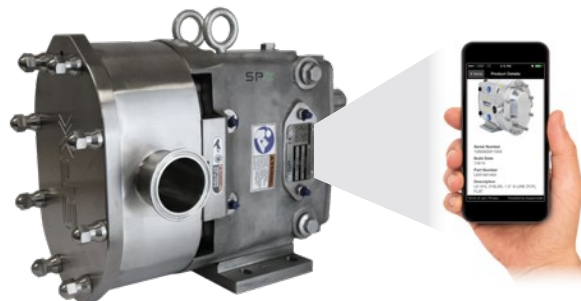

Performance and Long Life Through Design Excellence and Quality Construction

The Waukesha Cherry-Burrell Universal 3 Series gives you...

High pressure capability, up to 500 psi/34.5 bar, for more demanding jobs.

Longer service life, resulting from a fresh engineering approach and durable high quality components.

The right seal, for countless applications, plus interchangeability when needed

Metal rotor: Waukesha "88" non-galling alloy, for close running clearance.

Design conforms, to 3-A, ISO 9001:2015

DESIGNED WITH AN L-SHAPED COVER GASKET WHICH IS EASY TO CLEAN AND PREVENTS PARTICULATES FROM LODGING UNDER THE GASKET.

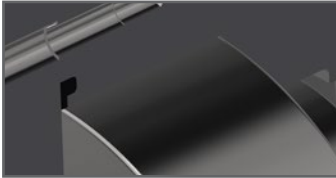

STANDARD 316L STAINLESS STEEL BODY AND COVER

STANDARD STAINLESS STEEL GEARCASE

FIELD INTERCHANGEABLE SEAL OPTIONS

- Seals located within the pump rotor and body

STANDARD STAINLESS STEEL BEARING RETAINERS

FRONT BEARING FIXED; REAR BEARING FLOATING. BETTER CONTROL OF THERMAL EXPANSION WHEN HANDLING HOT PRODUCTS

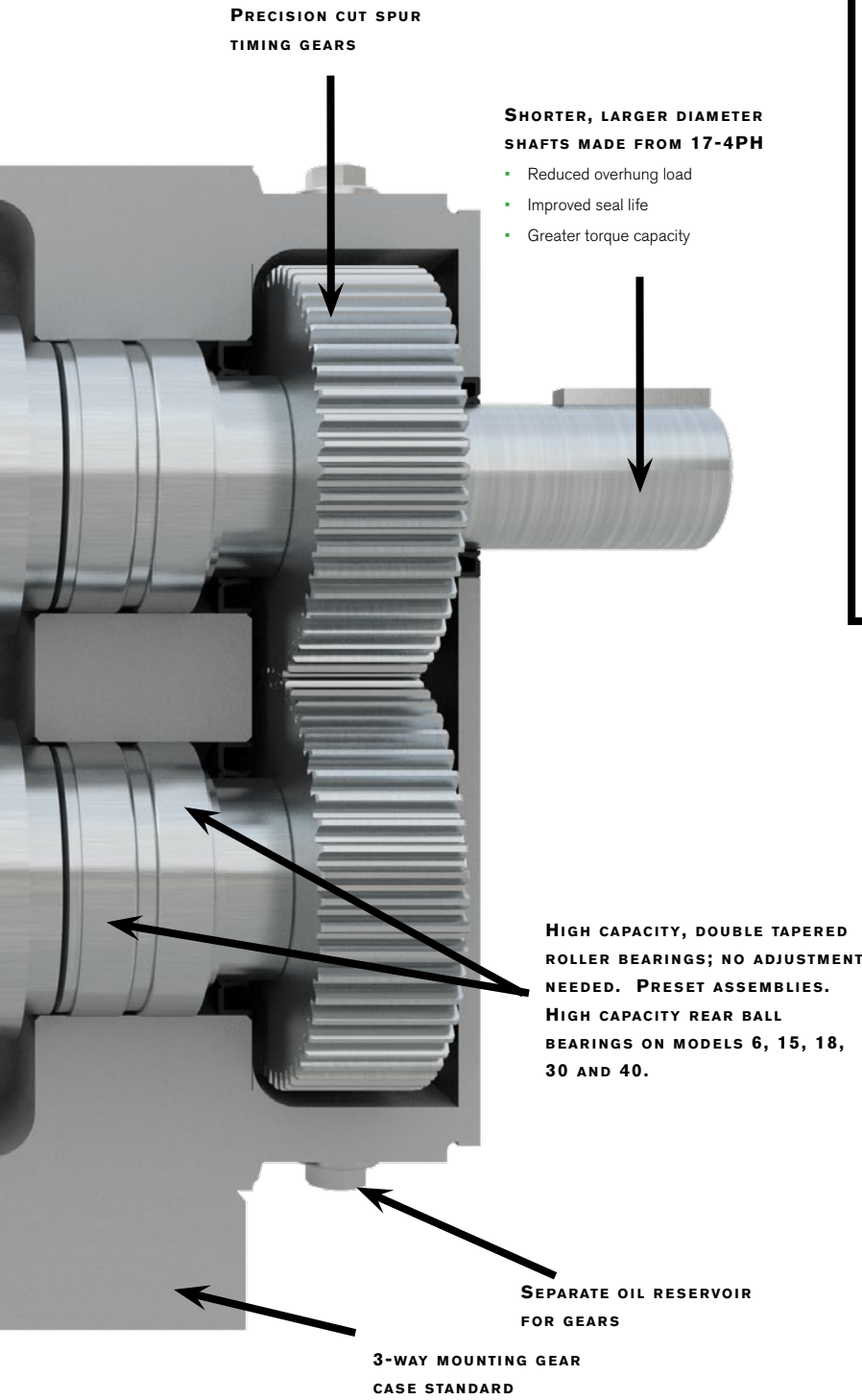

Seal Options

Single Mechanical Seal*

Standard seal configuration: silicon carbide rotary seal face and carbon stationary seal face. Alternate materials available for abrasive service.



Double Concentric Mechanical Seal*

Used with flushing fluid to cool, lubricate, flush away residue. Best arrangement for severe service.

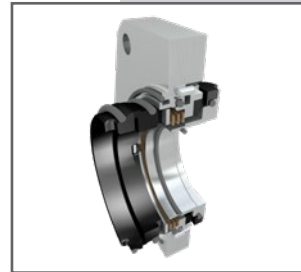

Single and Double O-ring Seal

Waukesha Cherry-Burrell's traditional general purpose seal. Low cost and easy to service. Suitable for low pressure applications. 100 psi, 7 bar

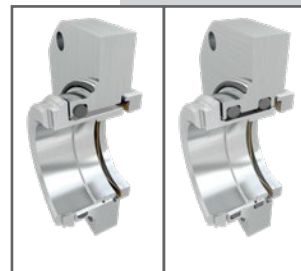

Elastomer choices for O-rings:

- Fluoroelastomer (FKM)
- EPDM
- Perfluoroelastomer (FFKM)

*Mechanical seal material options:

- Carbon
- Silicon Carbide
- Tungsten Carbide

STANDARD & OPTIONAL FEATURES

PORTS

Standard: Sanitary clamp type connections

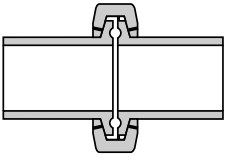

Available in a variety of styles including S-Line, I-Line and Q-Line

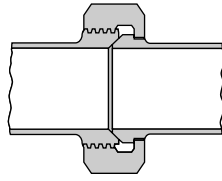

Bevel Seat Available

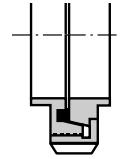

Optional European Types; DIN, SMS, RJT

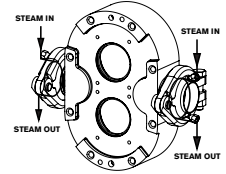

Optional Aseptic Ports

Male NPT and 150 lb. flanges optional on Models 006 through 220 size. 150 lb. flanges standard on Model 320.

ROTORS

Standard: Twin Wing

Suitable for most applications.

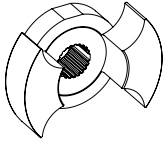

Rotor Clearance

- Standard for most applications up to 300°F (149°C).
- Low viscosity clearance rotors optional for applications up to 200°F (93°C).
- Contact application engineering for other rotor clearance options.

O-RINGS

Standard: Fluoroelastomer FKM

Fluoroelastomer (FKM), EPDM, Per Fluoroelastomer (FFKM)

COVER & GEARCASE

Standard: Stainless steel 17-4 shafts, top shaft position, stainless steel bearing retainers, shaft completely sealed from product zone.

Options:

- Lower shaft position
- Bearing isolators
- Pedestal shims for side mounted pumps. Left hand shaft position is standard
- Right hand shaft is positioned on side mounted gearcase

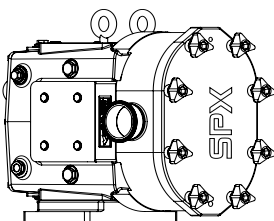
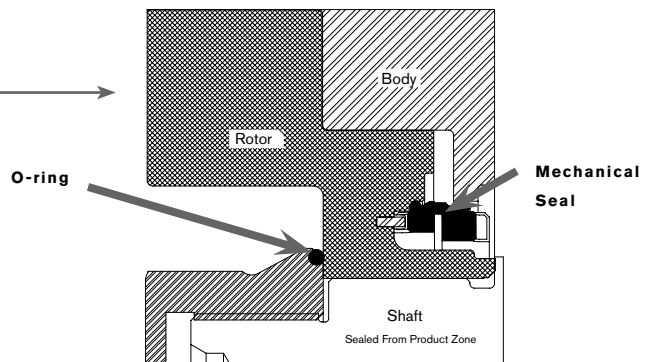

Shown with optional 3-wing cover nuts

SHAFT POSITION

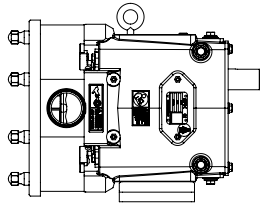

Top Shaft Position
Standard

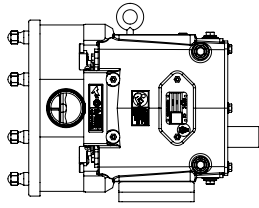

Lower Shaft Position
Optional

MOUNTING

Flat plate, epoxy painted, with adjustable feet, SS coupling guard, and Lovejoy or Woods coupling standard.

Options:

- 304 SS unpolished plate base with adjustable feet.
- Portable base with rubber wheels.
- SS tubular bases.

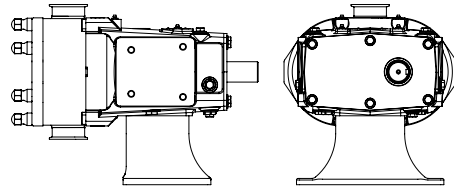

Standard left hand
shaft position shown
(right hand optional)

Optional Side Mount Gear Case for vertical
fluid entry and free draining of body

BASES AND DRIVES

Stainless steel tubular base with adjustable feet and stainless steel guard and coupling standard.

Options:

- 304 SS plate.
- Flat epoxy plate.
- Portable base.

TRU-FIT[®]

Close coupled Tru-Fit[®] pump mounted on stainless steel base with stainless steel adaptors standard.

Features:

- No shaft alignment necessary. No coupling guard required.
- Special base design enhances cleanability.
- Reduces overall length of complete unit by an average of 20-25%.
- Average of 20-25 gear ratios available per horsepower.
- Separate oil sump for gear reducer and timing gears.

Options:

- 304 SS polished plate base.
- NEMA or IEC frames available. Right angle reducer also available for additional space savings.
- 1/2 through 60 horsepower drive options available.
- Horizontal or vertical porting.

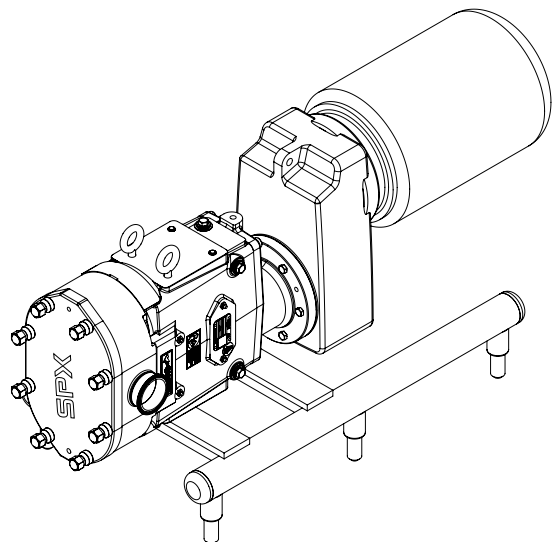

DIMENSIONAL DATA

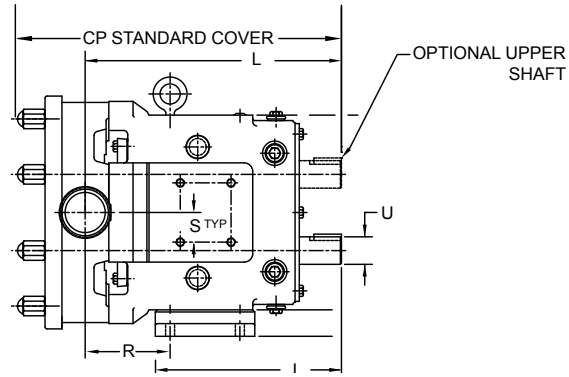
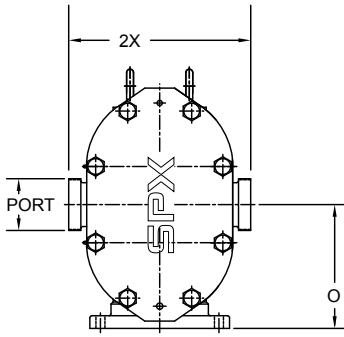

MODEL		CP	I	L	O	PORT SIZE	U +.000 -.001	2X	R*		
									U3	U1/U2	DIFF. BETWEEN U3 AND U1/U2 "R" DIM.
006-U3	IN	12.42	7.61	10.04	4.21	1.00	0.88	6.97	3.23	2.79	0.40
	mm	315	193	255	107	--	22	177	82	71	11
015-U3	IN	12.69	7.61	10.04	4.21	1.50	0.88	6.97	3.23	2.79	0.40
	mm	322	193	255	107	--	22	177	82	71	11
018-U3	IN	13.35	7.61	10.28	4.21	1.50	0.88	7.09	3.47	3.02	0.50
	mm	339	193	261	107	--	22	180	88	77	11.1
030-U3	IN	15.16	8.80	12.05	5.21	1.50	1.25	8.50	4.26	3.84	0.40
	mm	385	224	306	132	--	32	216	108	98	10.2
040-U3	IN	15.54	8.80	12.21	5.21	2.00	1.25	8.64	4.43	4.00	0.40
	mm	395	224	310	132	--	32	219	113	102	10.5
045-U3	IN	19.11	11.00	14.84	7.31	2"	1.63	10.75	4.72	4.73	SAME
	mm	485	279	377	186	--	41	273	120	120	
060-U3	IN	19.66	11.00	15.13	7.31	2.50	1.63	10.75	5.01	5.01	SAME
	mm	499	279	384	186	--	41	273	127	127	
130-U3	IN	20.68	11.00	15.76	7.31	3.00	1.63	10.75	5.64	5.65	SAME
	mm	525	279	400	186	--	41	273	143	144	
180-U3	IN	23.48	14.80	19.03	9.38	3.00	2.00	13.06	4.21	4.20	SAME
	mm	596	376	483	238	--	51	332	107	107	
210-U3	IN	27.07	17.72	21.85	10.38	4.00	2.38	14.73	5.64	4.70	0.90
	mm	688	450	555	264	--	60	374	143	119	24.3
220-U3	IN	24.22	14.80	18.49	9.38	4.00	2.00	13.25	4.45	4.44	SAME
	mm	615	376	470	238	--	51	337	113	113	
320-U3	IN	27.66	17.72	22.34	10.38	6.00 150# FLG	2.38	16.00	6.02	5.09	0.90
	mm	703	450	567	264		60	406	153	129	23.9

*"R" dimension shown for customers converting from a U1/U2 pump to a U3 pump. All other dimensions are the same between U1/U2/U3.

NOTE: Dimension "2X" applies for Bevel Seat, "S"-Clamp, "Q"-Clamp, 15I and 14I fittings (except 320-U3).

NOTE: Dimensions are for guidance purposes only. Contact your SPX FLOW Representative if more detailed measurements are needed.

UNIVERSAL 3 MODELS - TRU-FIT®

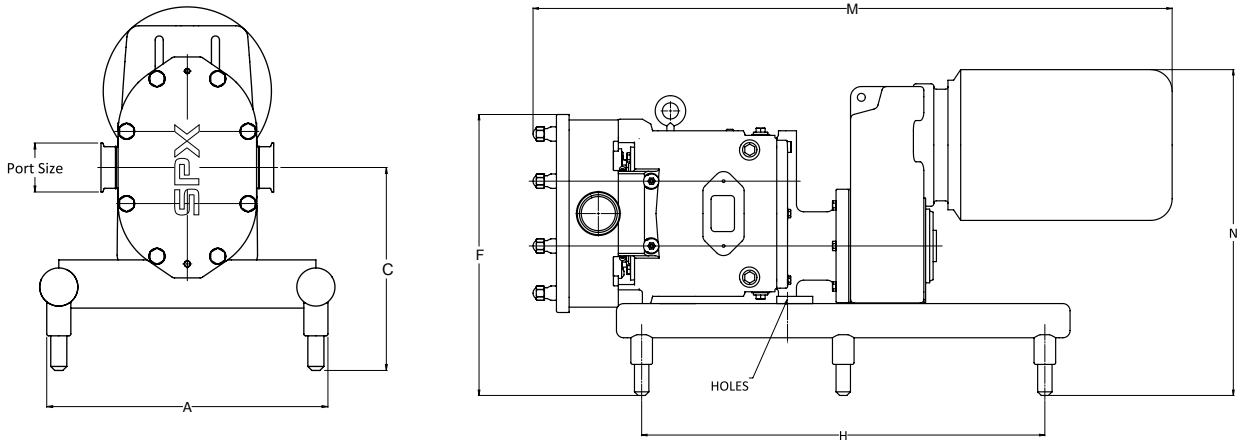

MODEL		A	C	F	H	M ¹	PORT SIZE	N ¹
006-U3	IN	14.38	9.81	13.90	18.00	28.02	1.00	16.22
	mm	365	249	353	457	712	--	412
015-U3	IN	14.38	9.81	13.90	18.00	28.29	1.00	16.22
	mm	365	249	353	457	719	--	412
018-U3	IN	14.38	9.81	13.90	18.00	28.29	1.50	16.22
	mm	365	249	353	457	719	--	412
030-U3	IN	14.38	11.03	16.10	20.00	34.24	1.50	19.68
	mm	365	280	409	508	870	--	500
040-U3	IN	14.38	11.03	16.10	20.00	34.61	2.00	19.68
	mm	365	280	409	508	879	--	500
045-U3	IN	18.38	12.63	19.51	28.00	44.24	2.00	22.65
	mm	467	321	496	711	1124	--	575
060-U3	IN	18.38	12.63	19.51	28.00	44.52	2.50	22.65
	mm	467	321	496	711	1131	--	575
130-U3	IN	18.38	12.63	19.51	28.00	45.54	3.00	22.65
	mm	467	321	496	711	1157	--	575
180-U3	IN	20.38	14.66	23.41	36.00	50.24	3.00	26.07
	mm	518	372	595	914	1276	--	662
220-U3	IN	20.38	14.66	23.41	36.00	50.98	4.00	26.07
	mm	518	372	595	914	1295	--	662

¹ Dimensions affected by motor frame size

NOTE: Dimensions are for guidance purposes only. Contact your SPX FLOW Representative if more detailed measurements are needed.



When it is time to replace ...

SPX FLOW offers a Pumps for Life™ program on Universal 3 models

Pumps for Life™ Program

Contact your Waukesha Cherry Burrell distributor to learn more about the Pumps for Life™ program and how to make sure your pumps qualify.

SPX FLOW Certified Pump Repair Centers

- Local distributors with factory trained and certified service technicians.
- Quick local response.
- Genuine WCB parts.
- Flexible repair programs to meet your needs.
- Local warranty support.



SPX FLOW Universal 3 Pump Warranty

Seller warrants its products to be free from defects in materials and workmanship for a period of two (2) years from the date of shipment.

This warranty shall not apply to products which require repair or replacement due to normal wear and tear or to products which are subjected to accident, misuse or improper maintenance. This warranty extends only to the original buyer. Products manufactured by others but furnished by seller are exempted from this warranty and are limited to the original manufacturer's warranty.

Based in Charlotte, North Carolina, SPX FLOW, Inc. (NYSE: FLOW) is a multi-industry manufacturing leader. For more information, please visit www.spxflow.com

SPX FLOW

611 Sugar Creek Road

Delavan, WI 53115

P: (262) 728-1900 or (800) 252-5200

E: wcb@spxflow.com

SPX FLOW, Inc. reserves the right to incorporate our latest design and material changes without notice or obligation.

Design features, materials of construction and dimensional data, as described in this bulletin, are provided for your information only and should not be relied upon unless confirmed in writing. Please contact your local sales representative for product availability in your region. For more information visit www.spxflow.com.

The green "x" and "x" are trademarks of SPX FLOW, Inc. Waukesha Cherry-Burrell® and Tru-Fit® are registered brands of SPX FLOW, Inc.

App Store® logo is a trademark of Apple Inc.

Google Play and the Google Play logo are trademarks of Google LLC.

WCB_Pumps-PD-U3-FH-1802_US

Version: 08/2020

COPYRIGHT © 2020 SPX FLOW, Inc.

Identification Number: FH-1802-US